

MOOG
VIDEOLARM

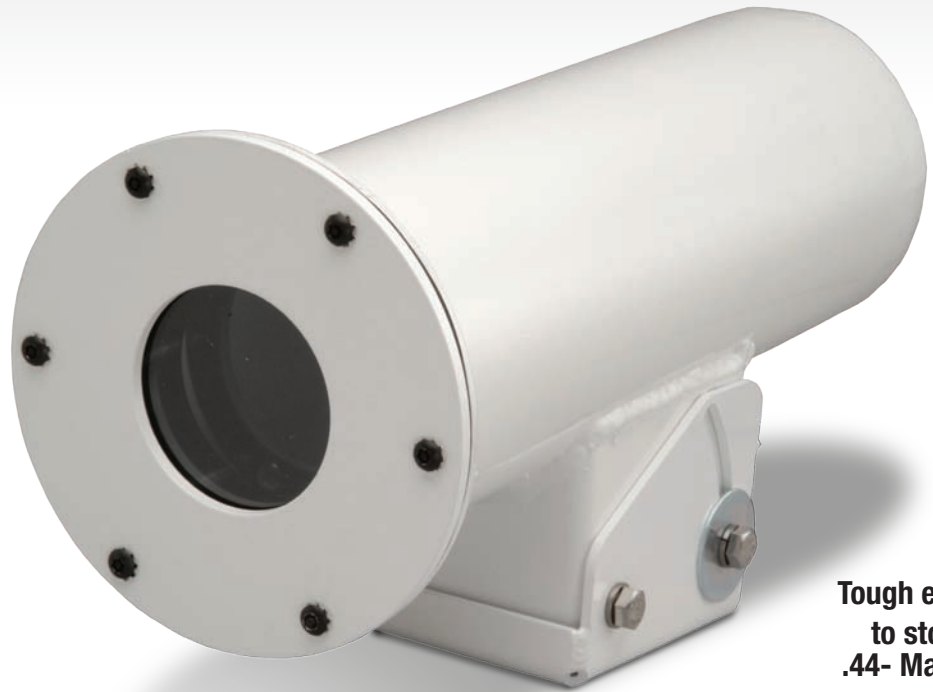

**Tough enough
to stop a
.44- Magnum
bullet!**

BMT10C/2/3 Bullet-Resistant Housing

Moog Videolarm's BMT10 unit is a bullet-resistant environmental camera housing featuring a 7-gauge steel body and is designed to meet or exceed Level III protection per UL standard 752. An integrated tilt bracket protects all wiring and allows for surface mount applications, plus an innovative camera sled allows the camera to be rotated 360° within the housing to allow for any mount position.

Key Features

- Accepts many lens and camera combinations up to 9.5"
- SP-1250 Lexgard® viewing window, with a Window Guard™ paint shield
- Rotating camera sled allows the housing to be mounted at any angle
- Constructed from 7-gauge steel for strength and durability
- Durable, heat reflective, white powder-coat finish
- Thermostatically controlled heater standard
- Integrated tilt bracket to protect wiring
- Designed to meet IP65 standards
- Optional sunshield

US Patent No. 6,375,369 B1



Outdoor Camera Housings:

BMT10C

Steel Bullet-Resistant Outdoor housing with Window Guard™ paint shield, plus 115Vac heater/thermostat (Level III). Tough enough to stop a .44 Magnum bullet

BMT10C2

Steel Bullet-Resistant Outdoor housing with Window Guard™ paint shield, plus 24Vac heater/thermostat. Tough enough to stop a .44 Magnum bullet

BMT10C3

Steel Bullet-Resistant Outdoor housing with Window Guard™ paint shield, plus 220/240Vac heater/thermostat. Tough enough to stop a .44 Magnum bullet

ACCESSORIES:



WMBMT
Ballistic wall mount for BMT10



VLAY10
Aluminum sunshield for BMT10



BMTWG
Replacement Window Guard™ paint shield (5 pack)

WINDOW GUARD PAINT SHIELD™:



Our exclusive Window Guard Paint Shield™ protects housing windows from vandals using spray paint or paint ball guns.

SPECIFICATIONS:

Electrical Specifications

Power Source:

Size (h*w*d):	6.74" x 4.52" x 13.74"
BMT10C:	120 Vac, 50/60Hz, 28 VA
BMT10C2:	24 Vac, 50/60Hz, 28 VA
BMT10C3:	230 Vac, 50/60Hz, 28 VA

The ballistic-rated environmental housing shall be constructed from 4.50" diameter steel tubing with a .23" thick wall, and shall include a thermostatically controlled heater. Front end plate shall be made from 7-gauge steel. The viewing window shall be constructed from SP-1250 Lexgard®, 1.25" bullet-resistant plastic with a vandal-resistant guard, and shall be bolted to the front end plate. The internal camera bracket, which will rotate 360° inside the housing, shall allow the housing body to be mounted on any angled surface. The enclosure shall have an integrated tilt bracket that protects wiring and also allows for surface mount applications. An optional .090" thick aluminum sun shield will be available. Both the housing and sun shield shall have a heat-reflective, white powder coat finish

Architectural Drawings

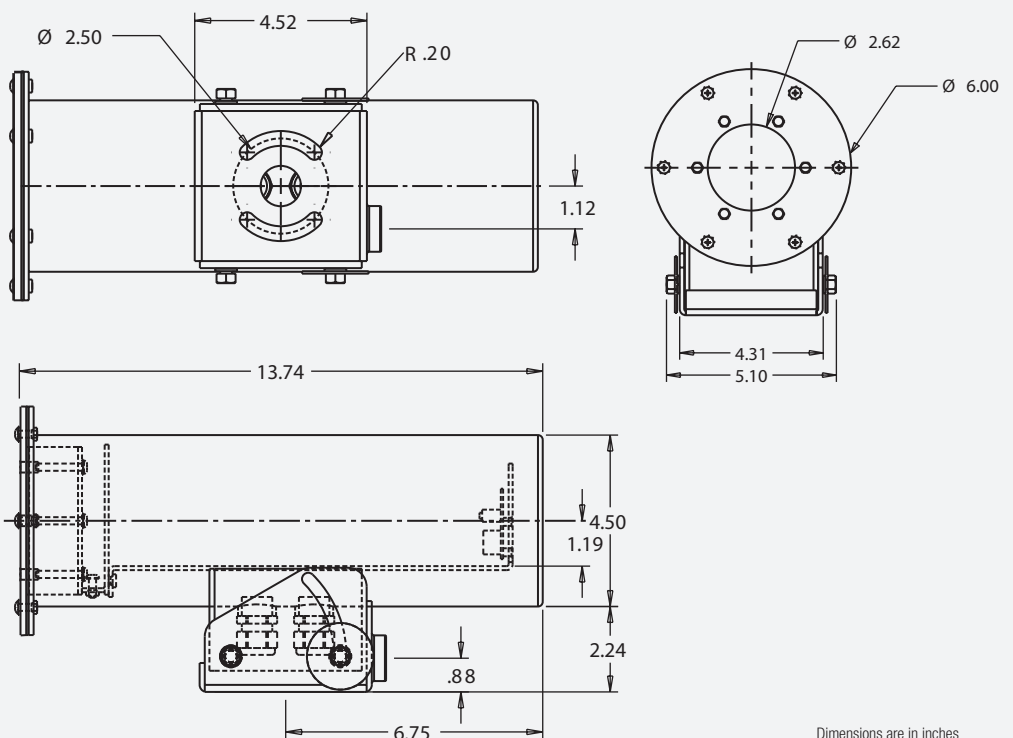

Certifications and Ratings



UL Listed



CUL Listed